



Uniform Doctor Blade Metering

How to Achieve Desired Results

By Bill Warner

Flexographic printing requires the doctor blade to provide uniform metering, so that the ink volume carried by the anilox to the plate is determined only by the anilox volume. If the doctor blade is not working correctly, the ink volume carried to the plate will include the anilox volume plus some amount of surface ink. Any surface ink remaining on the anilox will be variable leading to variation in the printed product.

In order to achieve uniform metering, the correct doctor blade needs to be used for the job and it needs to be installed and set properly. This article will provide guidelines on how to achieve uniform metering throughout the run.

A significant number of modern flexographic presses are running dual blade chambered inkers, so the information below is oriented to a chambered inker being used. If you aren't using a chambered inker, the same basic principles will also apply to single blade reverse angle blade holders.

BLADE SELECTION

There are many options in doctor blades, and the blade material you choose will have an effect on the metering quality and life of the blade. Typically, metal doctor blades will provide the best metering, followed by composites, and then plastic blades.

Within the category of metal blades, there is carbon, stainless, and long life tool steel materials. Any of them can have an extra coating applied to help them perform better. The shape of the tip will also have an effect on the metering quality, whether it is a rounded tip, lamella, or beveled edge. Typically you will want to run a thinner blade with a small polished working tip to be able to maintain a small blade footprint on the anilox roll.

All of these variables can be confusing and I suggest you work with your blade supplier to find the right blade combination for the type of jobs you run.

BLADE ANGLE

The blade contact angle (*Figure 1*) is fixed on a chambered inker system, so there isn't much you can do to control the

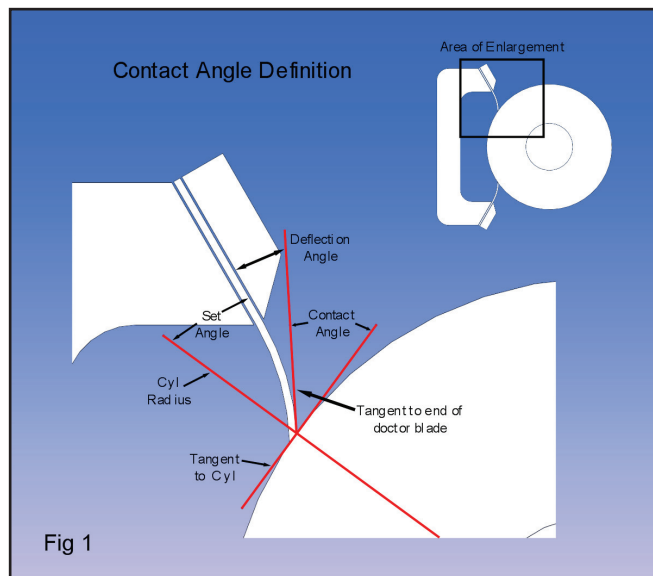

Fig 1

angle, other than running the chamber at the minimum applied pressure required to maintain a clean, uniform wipe.

A generally acceptable flexo doctor blade contact angle range is 25 to 42 degrees, depending on the system. A doctor blade contact angle of 30 degrees is a nominal good angle for preventing print defects. Flat angles, or angles less than 25 degrees, will not provide proper doctoring of anilox rolls, since they will require more force to doctor cleanly.

Too much force applied will quickly wear in a big flat, cause dot gain and inconsistent print, and possibly load dry ink and/or blade material into the anilox and damage it. Too sharp contact angles, angles greater than 42 degrees, can sometimes cause catching of the blade in the anilox cells, resulting in lines across the web or vibration and other related print defects.

Flexo containment blades should generally run flatter, about 20 degrees, and be thinner metal or flexible, but embedment resistant plastic should be used to prevent debris trapping and anilox wear or damage. Ideally, debris should pass easily under the containment blade and then be captured by a filter/magnet in the ink circulation system.

BLADE INSTALLATION

The method of installing the blade in the chamber is extremely important. If your blade clamping device uses bolts to secure the blade, be sure to tighten all the bolts the same by using a torque wrench set to an appropriate specification for the size of bolt being used.

Also, start in the center of the chamber and work out to the ends alternating from side to side. Before installing the doctor

METERING METRICS

- Blade material will have an effect on metering quality and life of the blade
- Metal blades typically provide the best metering, followed by composite and then plastic
- Acceptable contact angle range is 25-degrees to 42 degrees
- The correct doctor blade needs to be set and installed properly

ALLISON

Systems Corporation

220 Adams St.
Riverside, NJ 08075
(856) 461-9111
www.allisonblades.com

The doctor blade experts with over 40 years of technical knowledge are offering complete doctor blade solutions.



The largest variety of doctor blade materials and configurations to meet today's doctoring requirements.

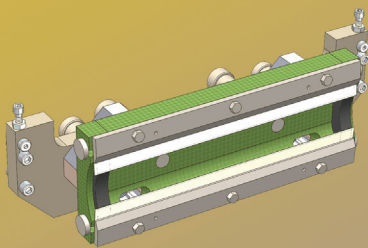

Custom designed flexo and gravure blade system retrofits that enhance doctor blade performance and repeatability.

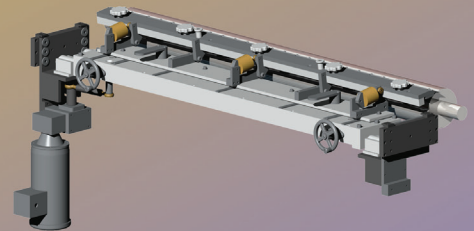

End seals for most flexo chambered inkers using either OEM or custom materials which stop leakage and increase seal life.

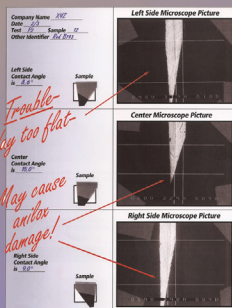

On site technical assistance, troubleshooting, and operator training services.



Let us help you... Contact us today!



blade, be sure that all of the components are clean and free of any damage. Inspect the components and repair any damage found if possible. Minor dings can usually be corrected by filing the damaged area smooth.

If the component is beyond repair, purchase a replacement part and take the damaged part out of service so that it can't be accidentally used. When installing the blade, be sure the back side of the blade is firmly resting on the ledge or pins that are built into the chamber. This will ensure that the doctor blade is installed parallel to the chamber. When the blade is not installed parallel to the blade holder, metering quality will likely suffer. Finally, after the blades are installed, look down the length of the blade to see if it is wrinkle free. If wrinkles are found, reinstall the blade after fixing the condition that caused the wrinkles.

ALIGNMENT TO ANILOX

When installing the chamber on the press, be sure to take the time to make sure the chamber is in alignment with the anilox roller. It is important that the chamber's centerline is aligned with the anilox roll centerline and that it is not skewed to the anilox roll. Be sure that both blades touch the anilox roll at the same time. Any misalignment between the doctor blade and the anilox roll will reduce the quality of the wipe that is delivered by the blade (Figure 2).

One way to check alignment is to use a plastic feeler gage. Remove the end seals from the chamber and move the chamber so that the blades are close to the anilox roll but not touching it. Slowly move the chamber closer to the anilox roll while sliding the feeler gage between the doctor blade and anilox roll on one end. Set the chamber position so that the feeler gage will slip between the blade and anilox roll with slight tension. Now check the gap between the rest of the blade and anilox roll. It should be the same everywhere on the blade and the same on the containment blade. Adjust the chambers position as necessary until there is uniform gap on both blades.

Be sure to follow any and all plant safety rules when checking the chamber alignment.

END SEAL EFFECTS

End seals that are not matched to the application can be a source of doctor blade problems because a poor fitting end seal or the wrong material will require extra applied pressure to stop leaks. End seals have one function in the flexo inking system and that is to prevent the ink from flowing out of the chamber.

Most end seals accomplish this by friction between the anilox and end seal and, depending on material, will rub

the anilox until it is worn beyond contact to the anilox. At that point the result is leakage, slinging ink, wasted substrate etc. The only corrective action is to replace the end seal with a new one and this can happen after only a few hours of production time.

On most presses with chambers and end seals, the doctor blade is also replaced with the end seal, even though the doctor blade may have many hours of life remaining. To extend end seal and blade life, the press operator must use the least possible force when setting the blade for printing. He must also understand and control one of the most common overlooked items in every pressroom, the ink pump and ink flow rate.

As press speed is increased, the ink force will add outward pressure to the end seal. To relieve some of this pressure, know your ink flow rate. Most chambers today use very little ink to fill the cavity, some as little as two pints. Measure the amount of ink required to fill your chamber and set your pump flow rate at slightly more than your chamber volume per minute. If you only need pints per minute and you are pumping gallons per minute, the end seal and doctor blade performance will likely degrade quickly and need to be replaced several times before the run is over.

Many flexo printers are moving away from diaphragm and centrifugal high flow pumps and utilizing dual feed peristaltic pumps that relieve the cavity pressure on end seals and blades. The dual feed pump can run the chamber at negative pressures thereby extending the life of doctor blades and end seals for longer production runs without changing either item.

APPLICATION PRESSURE

Application pressure has been mentioned a few times in this article. That is because excessive application pressure is a significant cause of inconsistent blade metering. Excessive pressure will over deflect the doctor blade, flatten the doctor blade contact angle, and prevent uniform blade metering.

Extreme pressures can deflect the blade to the extent that the blade tip will lift. A lifted blade tip can trap hard particles under it and lead to anilox scoring (Figure 3). At the very least,

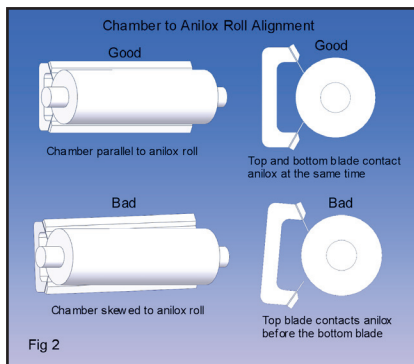

Fig 2

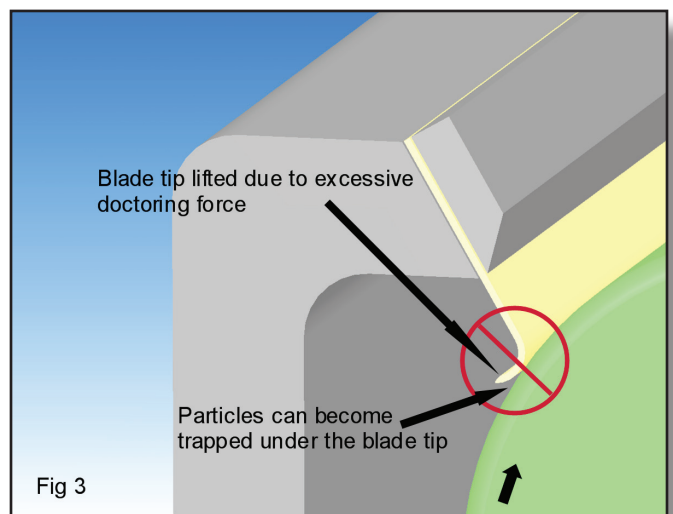

Fig 3

excessive pressure will increase the wear on the blade and anilox roll—both of which are undesirable.

So, how do you know what the wiping pressure should be? The blade wiping pressure should be low enough to obtain a clean wipe and maintain minimum blade deflection thru the printrun. Remember, the ink pressure on a reverse angle blade increases as the press speed increases. If the doctor blade is setup with deflection at idle, it may over deflect at high production speeds. Using a stiffer blade or thicker doctor blade is not the answer to solving this phenomenon; correct application pressure is the way to control blade deflection.

If your chamber system is air loaded, set the application pressure by adjusting the air pressure after initial forward movement of the chamber system. It may require a larger pressure to move your chamber forward, but after the chamber has moved into position, lower the pressure to zero and use a plastic feeler gauge to set the blade pressure. Gradually increase the air pressure until the feeler gauge fits snugly between the blade tip and anilox. Use the same procedure to adjust mechanically loaded chamber systems by using the adjustment mechanisms provided.

The message is the same for either system of applying pressure, when a new blade is installed, adjust the chamber so that the minimum amount of pressure is being applied to the blades as described above. Any additional pressure

will have a negative effect on doctoring uniformity. If you must add more air pressure to prevent end seal leakage, or achieve proper metering, you may be using the wrong end seal for your application, or you may have damaged or misaligned chambers.

CONCLUSION

The doctor blade is a critical part of the precision process that is flexographic printing. When treated as such, it will perform well and deliver the consistent metering that is required.

John Wooden, the hall of fame basketball player and coach, is quoted as having once said, "If you don't have time to do it right, when will you have time to do it over?" These words certainly apply to doctor blade selection and application. Take the time that is necessary to choose the correct doctor blade for your job and set it up correctly. If you believe you have taken the necessary steps and still have blade related issues, work with your blade supplier to resolve the situation. ■

About the Author: Bill Warner is vice president of Allison Systems Corp. He has 24 years of experience working with doctor blades and developing custom retrofit doctor blade systems for flexographic, gravure, and other printing processes. He can be reached at 856-461-9111 or wjwarner@allisonblades.com